

## Product Features

- Adjustable water temperature
- Soft aerated water flow
- Easy grip wide handle
- Smooth handle rotation
- High corrosion & tarnish resistant
- Easy maintenance

## Product Specification

- Installation type : Deck mounted
- Dimension : 160(L) x 52(W) x 164(H)mm
- Material : Brass
- Finishing : Chrome
- Water inlet size : G1/2"
- Operating water pressure : 1.5 -5 bars (dynamic)
- Water stream : Aerated



## Model Code

### W2-R-MXB8701

Code	WELS	Water flow rate (l/min)	WELS registration no.	Registration country
W2-R-	✓✓	Nominal 2	<ul style="list-style-type: none"> <li>• MXB8701 : BST-2020/030475/SLS</li> <li>• MXB8701-BM : BST-2020/030476/SLS</li> <li>• MXB8701-BZ : BST-2020/030477/SLS</li> <li>• MXB8701-BZP : BST-2020/030478/SLS</li> <li>• MXB8701-GM : BST-2020/030479/SLS</li> <li>• MXB8701-GP : BST-2020/030480/SLS</li> <li>• MXB8701-RG : BST-2020/030481/SLS</li> <li>• MXB8701-RGP : BST-2020/030482/SLS</li> </ul>	SG
RL-	N.A	2 - 6 configurable	N.A	N.A

Code	Available Colour & Finishes	
(NIL)	Chrome	
-BM	Black Matte	
-BZ	Bronze Matte	
-BZP	Bronze Polished	
-GM	Gold Matte	
-GP	Gold Polished	
-RG	Rose Gold Matte	
-RGP	Rose Gold Polished	

Rev	0.1
Date	30.10.2020

**DISCLAIMER** : While every effort has been made to ensure factual accuracy, the information presented is subject to changes due to requirements in different sites, markets and / or countries. Rigel reserves the right to make the necessary amendments at any time without prior notice.

## Technical Drawing

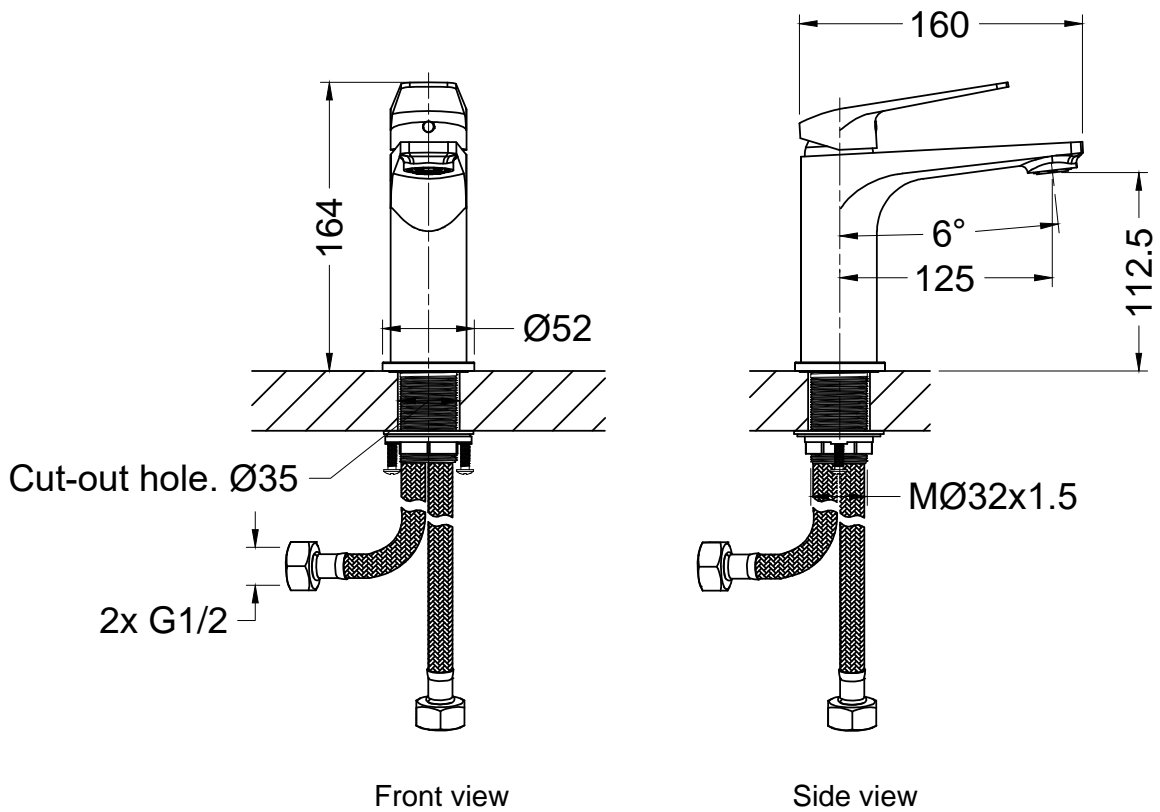

Copyright © Rigel Technology (S) Pte Ltd All rights reserved.

( ) Denotes recommended value.  
All dimension are in mm.

Rev	0.1
Date	30.10.2020

**DISCLAIMER :** While every effort has been made to ensure factual accuracy, the information presented is subject to changes due to requirements in different sites, markets and / or countries. Rigel reserves the right to make the necessary amendments at any time without prior notice.